

## Satellite Network Emulation for 4G/5G Communications

### Part 3: Signal Monitoring and Analysis with Boonton, CommAgility, and Holzworth

#### Product Demo:

Part 3 of the test set-up receives, monitors, and analyzes the transmitted signals that were sent through the simulated satellite network. The Holzworth Real-Time Phase Noise Analyzer performs objective measurements, testing the fidelity of the signal. Phase noise reduces signal quality, and therefore increases the error rate of the communications link. Holzworth products can test the cumulative phase noise created by an increasing density of satellite communications systems.

Boonton products enable a wide range of RF power measurements and signal analysis to monitor the overall system power level, performance, and signal degradation. Considering new modulations schemes like OFDM, measurements like crest factor (peak-to-average) can be a better figure of merit in determining the overall performance of amplifiers in satellite communications systems. Lastly, the CommAgility 4G/5G Management Tool allows for objective and subjective evaluations of the client user experience, providing a user-friendly and cost-effective graphical interface for monitoring and manipulating various configuration parameters.

#### Target Users:

Target users include system engineers and RF wideband amplifier designers using 4G/5G modulation schemes like OFDM and QAM for LEO/MEO satellite communications systems.

#### Test Set-Up:

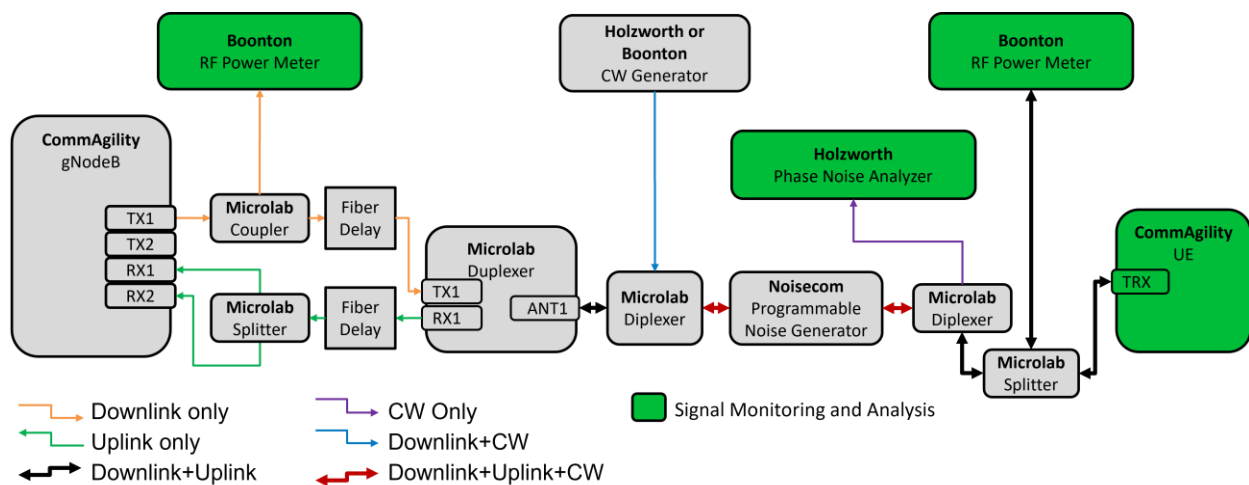

**About the Boonton RTP5000 Series:**

Backed by Boonton Real-time Power Processing (RTPP) technology, Boonton RTP5000 Series sensors are ideal instruments for RF power measurements that provide 100,000 measurements per second, 3 nanosecond rise times, 195 MHz of video bandwidth, and 100 picosecond time resolution to ensure gap-free signal acquisition and zero measurement latency.

**Significant Features:**

- 16 automated pulse measurements
- Synchronized multi-channel measurements
- Advanced measurement and analysis software with the Boonton Power Analyzer

**About the CommAgility 4G/5G Management Tool:**

Compatible with CommAgility 4G/5G Protocol Stack, Reference gNodeB, and Reference UE products, the 4G/5G Management Tool saves effort, time, and cost for monitoring and manipulating configuration parameters with an easy-to-use graphical interface. Parameters are validated to ensure safe operation and eliminate time lost to incorrect or mistyped data

**Significant Features:**

- Parameters that can be monitored include CPU statistics, uplink N+1 histogram, uplink N+1 per PRB, data plane statistics, data plane BLER, and control plane

**About the Holzworth Phase Noise Analyzer:**

Holzworth Real-Time Phase Noise Analyzers are optimized for measurement speed, z540 traceable accuracy, and high reliability. Holzworth analyzers are capable of reaching theoretical measurement limits for the highest performing devices under test (DUTs). Holzworth applies an ANSI z540 calibration to every analyzer built, creating full data traceability.

**Significant Features:**

- Measurement of noise floor: < -190 dBc/Hz at 10 kHz OS
- DUT input frequency range of 10 MHz to 40 GHz

**More Resources:**

Visit [info.wtcom.com/satellite-2022](http://info.wtcom.com/satellite-2022) to learn more about satellite communications solutions from Boonton, CommAgility, and Holzworth.