

On-Wafer Passive Load Pull for 5G FR2

During nonlinear analysis, high-frequency and high-power devices exhibit smaller impedances at their input and output, necessitating test and measurement tools capable of providing a complete, comprehensive evaluation in highly reflective areas.

In addition, electromechanical tuners in measurement and test setups introduce phase skew into modulated signal analysis and evaluation. This undesired effect depends on factors such as the physical distance between the DUT and tuner, dimensions of the tuner, and signal bandwidth. The direct probe-mount capability and compact size of the Maury Microwave Nano5G™ automated impedance tuner greatly minimize phase skew.

This demonstration features a vector-receiver source-pull and load-pull setup, utilizing two Nano5G tuners (one at the source and the other at the load) to manipulate source and load impedance and optimize the performance of a high-frequency, high-power device. Being VNA-based, the measurement setup provides vectorial data with essential parameters such as phase response and measured input impedance.

The compact size of the tuners facilitates easy installation, with probes mounted directly to the tuners' integrated couplers. As a result, the test setup reduces insertion loss, shortens the physical distance between the tuner and DUT, maximizes control capability on the Smith Chart over a larger area, and decreases total phase deviation.

Demo Setup

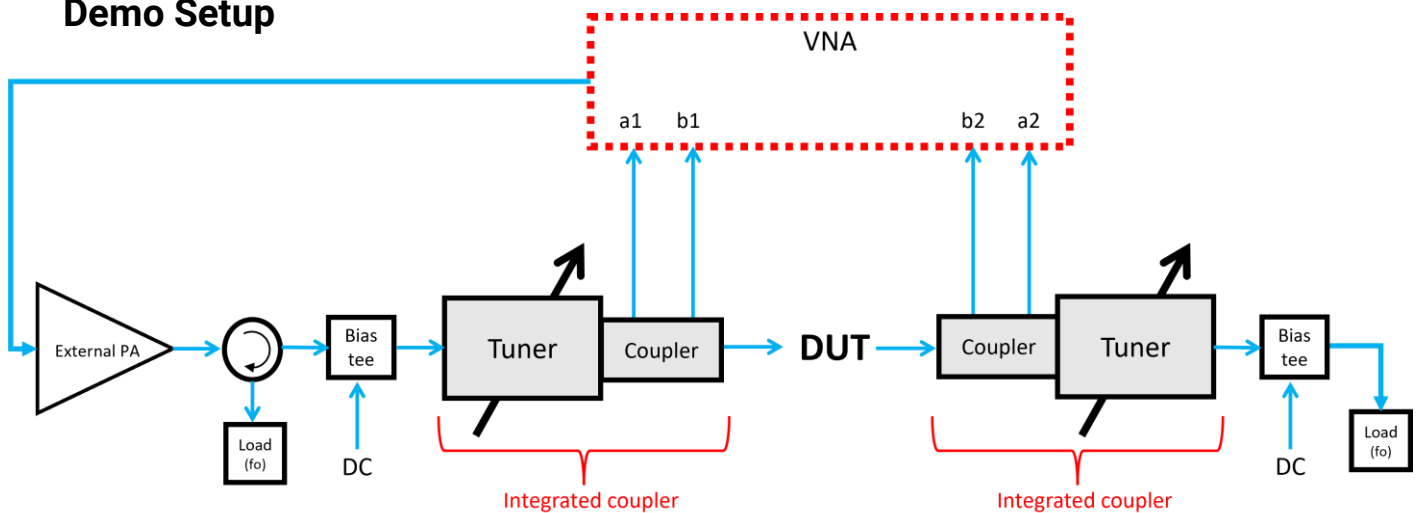

Target Users

Targets users include modeling, test and verification, reliability and quality, and R&D engineers focused on reliability testing and design/model verification for 5G communications systems above 18 GHz.

Product Overview

Nano™ Series Automated Impedance Tuners

The Nano series (NT-series) automated impedance tuners are designed for on-wafer applications with maximum VSWR at the probe tip. The Nano5G model enables highly reliable passive load pull measurements for 5G applications, especially in the 28 GHz and 39 GHz bands allocated for FR2, although continuous operation is available from 18 GHz – 50 GHz.

Miniaturized using state-of-the-art actuator technology, the Nano series connects directly to a probe, eliminating the probe mount or cable typically placed between the tuner and DUT. Optimizations include low-profile RF connections, a cable management bracket that minimizes cable movement, and the option to integrate low-loss high-directivity couplers to further eliminate sources of insertion loss.

Integrating the Nano series into a passive on-wafer load pull measurement system enables engineers to maximize tuning range and minimize phase skew, which are both critical test considerations for power amplifier developers and circuit designers.

KEY SPECIFICATIONS AND FEATURES:

- Frequency range: 18 GHz to 50 GHz
- VSWR matching range:
 - Minimum: 10:1
 - Typical: 40:1 @ 28 GHz, 39 GHz
- Step size:
 - Probes: 3.94 microinches
 - Carriage: 3.94 microinches
- Connectors: precision 1.85mm, M/F
- Maximizes tuning range
- Reduces phase skew
- Eliminates the need for external probe mounts, cables, and couplers
- Minimizes transmission line lengths by bringing turning element closer to the DUT

More Resources

Visit info.maurymw.com/ims-2024 to learn more about Maury Microwave solutions.

