

Wideband Impedance Control at 5G FR2

With the growing importance of wireless applications and increasing use of high data rate protocols, optimizing the linearity and efficiency of amplifiers has become crucial. The preferred large signal characterization test bench (passive load pull) faces significant challenges. Losses and electrical delay from tuners, cables, and probes constrain the system, limiting the reflection coefficient that can be provided to the DUT.

This demonstration performs load pull on a low-noise amplifier (LNA) using the Maury Microwave MT2000 mixed-signal active load pull system. It will showcase fundamental frequency modulated load pull of 20 impedance states and power sweep at 26 power levels. All impedances over the modulated bandwidth of 200 MHz are set to a single impedance state.

The MT2000 can perform load pull at high speeds – up to 1000 impedance/power states per minute – with no limitation on Smith chart coverage. This turnkey solution offers wideband impedance control for modulated signals over the hardware's modulation bandwidth. It uses automatic signal pre-distortion to create a clean modulated signal at the DUT reference plane and can set all impedances over the modulated bandwidth at a single impedance point. Standard measurement parameters include adjacent channel power ratio (ACPR), error vector magnitude (EVM), and spectral mask.

Demo Setup

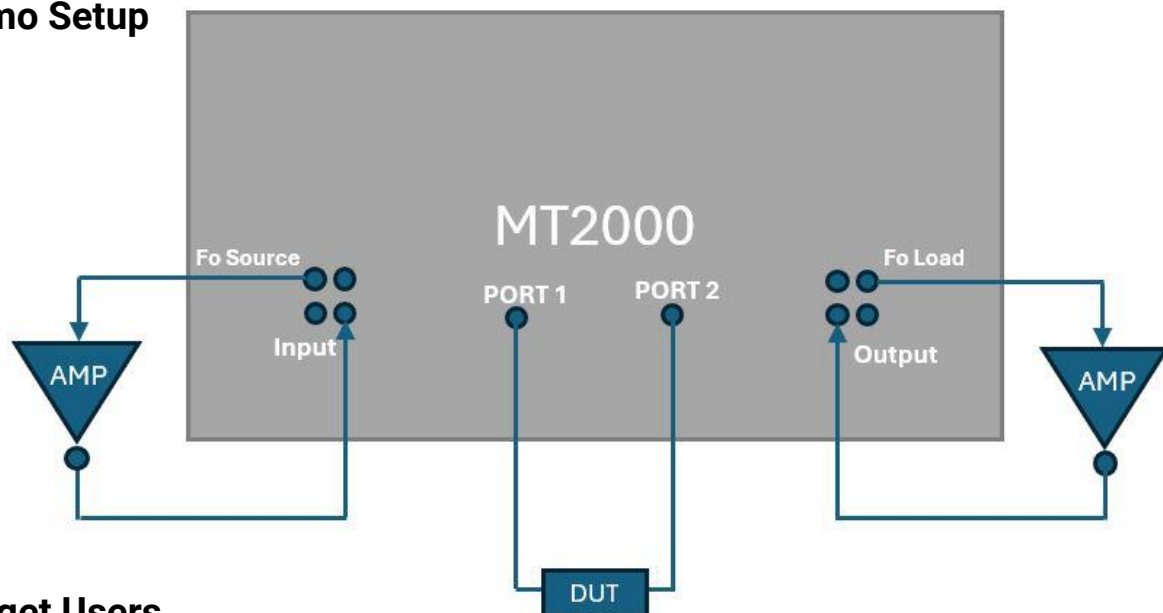

Target Users

Target users include designers of wireless and microwave systems, antennas, and semiconductor devices engaged in technology development, compact model device extraction and validation, and design activities with specific needs related to advanced, high-speed, wideband communications systems.

Product Overview

MT2000 Mixed-Signal Active Load Pull System

The MT2000 is a turnkey one-box load pull solutions that replace the functions typically performed by passive fundamental and harmonic impedance tuners, VNAs, NVNAs, analog signal generators, vector signal generators, vector signal analyzers, and oscilloscopes. Moreover, the solution adds the capabilities of high-speed load pull measurements and wideband impedance control for modulated signals. By combining multiple bench setups into a single box, offering unrivaled load pull speeds, and maximizing Smith chart coverage, the MT2000 is a powerhouse for device characterization, validation of nonlinear compact models, and extracting nonlinear behavioral models.

KEY SPECIFICATIONS AND FEATURES:

- Performs load pull at high speeds of up to 1000 impedance/power states per minute with limitation-free Smith chart coverage under the following conditions:
 - Single-tone CW and pulsed-CW RF signal
 - DC and pulsed-DC bias
 - Time-domain NVNA voltage and current waveforms and load lines
 - Fundamental and harmonic impedance control on the source and/or load
 - Frequencies between 1 MHz and 67 GHz
- High-speed load pull with high magnitudes of reflection coefficients ideal for:
 - Reducing time-to-market due to faster measurement speeds
 - Minimizing bottlenecks caused by traditional passive mechanical load pull systems without a loss of accuracy
 - Validating nonlinear compact models
 - Extracting nonlinear behavioral models
 - R&D, design validation test, and on-wafer production test
- Wideband impedance control of up to 1000 MHz bandwidth at the fundamental, harmonic, and baseband frequencies and is optimal for:
 - Using ACPR/EVM measurement data in the design of wideband PA circuits
 - Improving PA linearity based on controlled baseband terminations
 - Evaluating the performance of a DUT under realistic antenna load conditions and different matching network topologies

More Resources

Visit info.maurymw.com/ims-2024 to learn more about Maury Microwave solutions.

